

Hall effect Current Sensor

SCK16

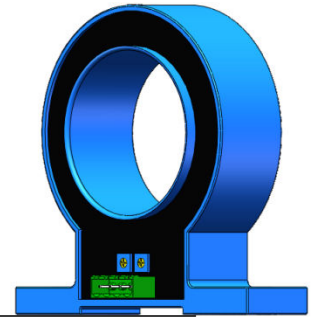

Product description

Features

- Based on Hall effect measurement principle, open loop circuit mode.
- The isolation voltage between primary and secondary is greater than 3000VAC.
- Comply with UL94-V0 flame retardant rating.

Performance

- It can measure DC, AC, pulse, and various irregular waveform currents of cable conductors under isolation conditions.
- Wide measurement range, fast response speed, low zero drift, low temperature drift, high accuracy and good linearity.
- Dynamic performance (di/dt and response time) is optimal when the busbar is fully filled with primary perforations.
- Strong ability to resist external electromagnetic interference (BCI, EFT, CS, CE, ESD, dv/dt, etc.).

Application

- It can be widely used in inverters, UPS, photovoltaic inverters, electric vehicle drives, high-frequency power supplies, inverter welding machines and other products.

Implementation standards

- GB/T 7665-2005
- JB/T 7490-2007
- JB/T 25480-2010
- JB/T 9473-2020
- SJ 20792-2000

Certification



Shenzhen SoCan Technologies Co.,Ltd

SoCan is committed to continuously improving product quality, and the company reserves the right to update its products.

www.szsocan.com

Technical Parameters

Model Parameters (25°C)	SCK16T-						
	300A	400A	500A	800A	1000A	1200A	1500A
Primary Current (A) I_{PN}	300A	400A	500A	800A	1000A	1200A	1500A
Primary Current Max. Peak Value (A) I_{PM}	±900A	±1200A	±1500A	±2400A	±2400A	±2400A	±2400A
Output voltage (V) V_{out} @± I_{PN} , $R_L=10K\Omega$	±4V±1%						

Electrical Data

Item	Min.	Typical	Max.	Unit
Input power supply voltage range V_c (±5%) (Remark 1, Remark 2)	±11	±15	±18	V_{DC}
Current consumption I_c	-	±15	±20	mA
Withstand resistance R_{INS} @500V DC	1000	-	-	$M\Omega$
Output voltage V_{out} @ I_{PN} , $R_L=10K\Omega$, $T_A=25^\circ C$	3.960	4.000	4.040	V
Output internal resistance R_{OUT}	-	102	-	Ω
Load Resistance R_L	1	10	-	$K\Omega$
Accuracy X @ I_{PN} , $T_A=25^\circ C$	-	±1	-	%
Linearity ϵ_L @ $R_L=10K\Omega$, $T_A=25^\circ C$	-	±0.5	-	% I_{PN}
Offset voltage V_{OE} @ $T_A=25^\circ C$	-	±10	±20	mV
Hysteresis voltage V_{OM} @ $I_{PN} \rightarrow 0$	-	±10	±20	mV
Temperature Coefficient of Offset Voltage TCV_{OE}	-	±0.5	±1	mV/ $^\circ C$
Output voltage temperature coefficient TCV_{out}	-	±0.05	±0.1	%/ $^\circ C$
Response time t_D @ $0 \rightarrow I_{PN}$	-	3	5	us
Ambient operating temperature T_A	-40	25	125	$^\circ C$
Ambient storage temperature T_s	-40	25	125	$^\circ C$
Withstand voltage V_D @50Hz,60s,0.1mA		3000		V_{AC}
Weight m		310		g

Remarks:

Shenzhen SoCan Technologies Co.,Ltd

SoCan is committed to continuously improving product quality, and the company reserves the right to update its products.

www.szsocan.com

1. VC is less than the minimum value, which will lead to inaccurate measurement, VC is greater than the maximum value, which may cause permanent failure of the measurement device.
2. When $\pm 12V < VC < \pm 15V$, the measurement range will be reduced.

$$3. V_{OUT} = 4.04 * \frac{R_L}{102 + R_L} * \frac{I_P}{I_{PN}} + V_{OE}$$

4. Follow the speed $di/dt > 50A/uS$

Dimensions (in mm)

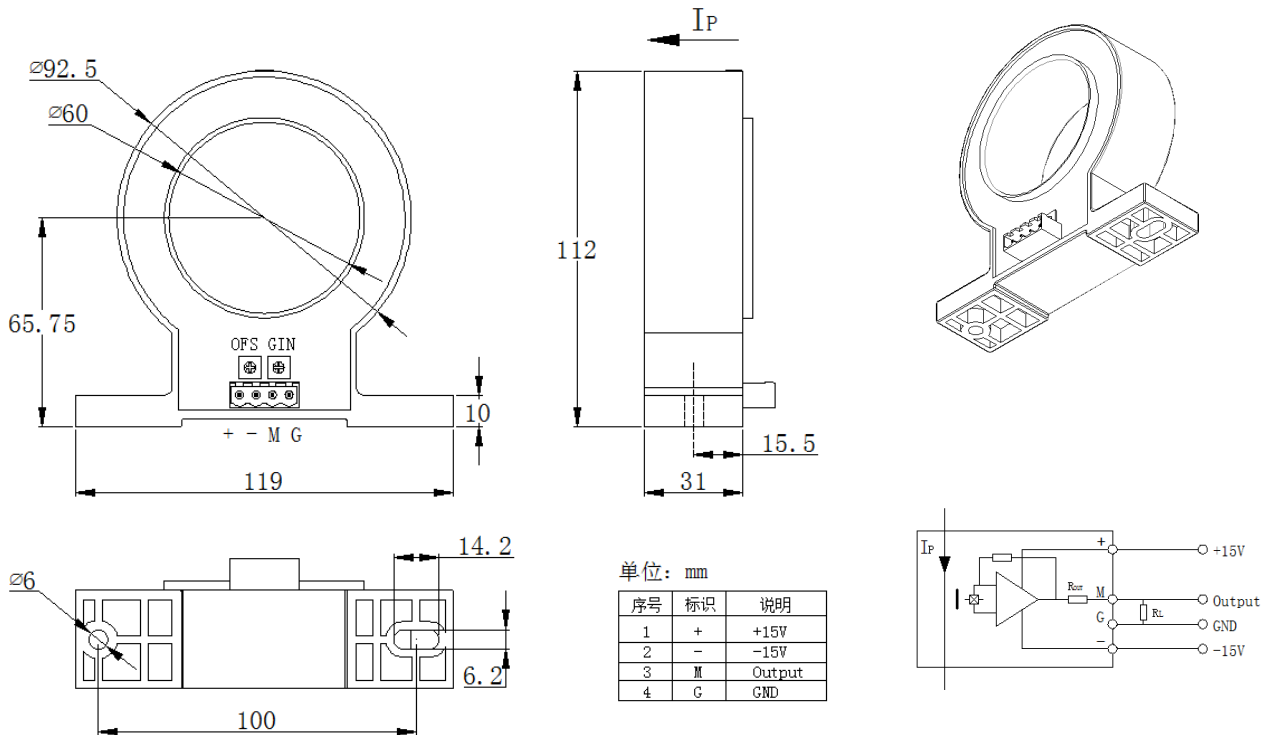

Notes:

1. Size error: $\pm 1mm$;
2. Primary aperture: $\phi 60mm$;
3. Fastening hole: $\phi 6mm * 2$;
4. Output terminal: 2EDGVC-5.08-4P;
Mating plug: 2EDGK-5.08-4P;
5. The IP indication direction is the positive direction of the current, OFS is the zero adjustment, and GIN is the output regulation;
6. The temperature of the primary conductor shall not exceed $105^{\circ}C$;
7. Incorrect wiring may cause damage to the sensor.

Shenzhen SoCan Technologies Co.,Ltd

SoCan is committed to continuously improving product quality, and the company reserves the right to update its products.

www.szsocan.com